

AGATHA SERIES PENDANT LIGHT

KEY FEATURES

Decorative aluminium hand spun LED pendant

Replaceable E27 Philips Deco fixed output LED lamp or warm dimming Master LED lamp

Available in three desirable colourways as standard

Supplied with colour coordinated ceiling cup
Bespoke paint finishes available

Red braided cable option

Adjustable 2m suspension cable

Interior finish in white satin



DIMENSIONS

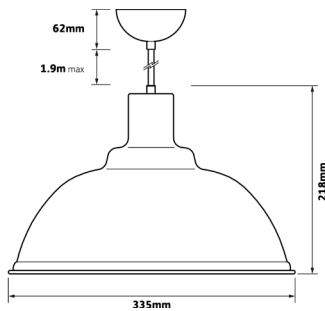

EM

PRODUCT
PV
VARIATION



TECHNICAL SPECIFICATION

MODEL NUMBER	W	lm	K
OL-AGATHA-01	6	370lm	2,200 - 2,700K
OL-AGATHA-02	7.5	500lm	2,700K

Fabiia, G08, The Light Box, 111 Power Road, Chiswick, London W4 5PY, United Kingdom.
contact@norse.lighting | www.norse.lighting

AGATHA SERIES PENDANT LIGHT

PHOTOMETRIC DRAWINGS

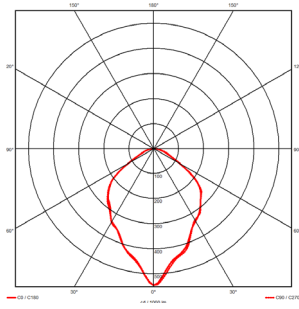

Fabiia, G08, The Light Box, 111 Power Road, Chiswick, London W4 5PY, United Kingdom.
contact@norse.lighting | www.norse.lighting